



**COLORADO  
COLLEGE**

# Getting Ready for School Tomorrow

*ACIS*

*October 11, 2024*

*Dr. Manya Whitaker*





**COLORADO  
COLLEGE**

## Who Am I?

- Interim President
- Professor of Education
- Developmental Educational Psychologist
- Social and Political Issues in Education
- Educational Consulting
  
- *NOT a classroom teacher*





**COLORADO  
COLLEGE**

## Overview

- Landscape of Higher Education
- Student Development Across Time
- Distinct Strategies
- Opportunities for Independent Schools
  
- *What can we learn from higher ed's mistakes?*



**COLORADO  
COLLEGE**

## Hot Topic Issues

- Affordability & Opportunity
- Career Readiness
- Mental Health & Wellness
- Academic Preparedness

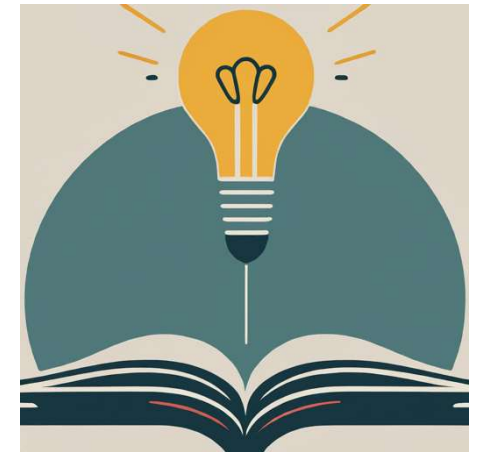
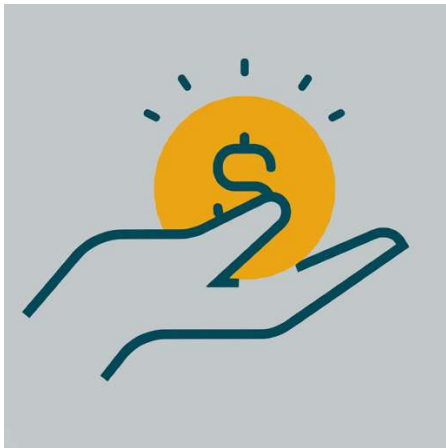



**COLORADO  
COLLEGE**

## **The Schoolyard**

### **PK-12 Independents**

- Ages 3-18
- Teacher shortage
- Teacher training
- College
- Family engagement
- Prescriptive pedagogy

### **Higher Ed**

- 18+
- Faculty excess
- Faculty training
- Post-graduate success
- Adolescent brain
- Freestyle pedagogy



**COLORADO  
COLLEGE**

## Generation Wars

### **Gen Z (1997-2012)**

- Technology natives
- Personalization
- Inclusivity
- Values-driven
- Personal development
- Social isolation
- Less sleep

### **Gen Alpha (2012-2026)**

- Technology savants (AI)
- Customization
- Equity and empowerment
- Collective values-driven
- Collective development
- Socially overwhelmed
- Even less sleep



**COLORADO  
COLLEGE**

## Developmental Assets

- **Social Skills**
  - Advocacy
  - Venturesomeness
- **Emotional Skills**
  - Sympathetic
  - Hopeful





**COLORADO  
COLLEGE**

## Developmental Assets

- **Cognitive Skills**
  - Digital literacy
  - Resourceful
  - Creative
  - Information-processing
  - Divided and selective attention







**COLORADO  
COLLEGE**

## Developmental Concerns

- **Social Skills**
  - Identity development
  - Conflict resolution
- **Emotional Skills**
  - Resilience
  - Self-regulation
  - Independence





**COLORADO  
COLLEGE**

## Developmental Concerns

- **Cognitive Skills**
  - Synthesis and evaluation
  - Cognitive drain
  - "Trauma-brain"
  - Sustained attention

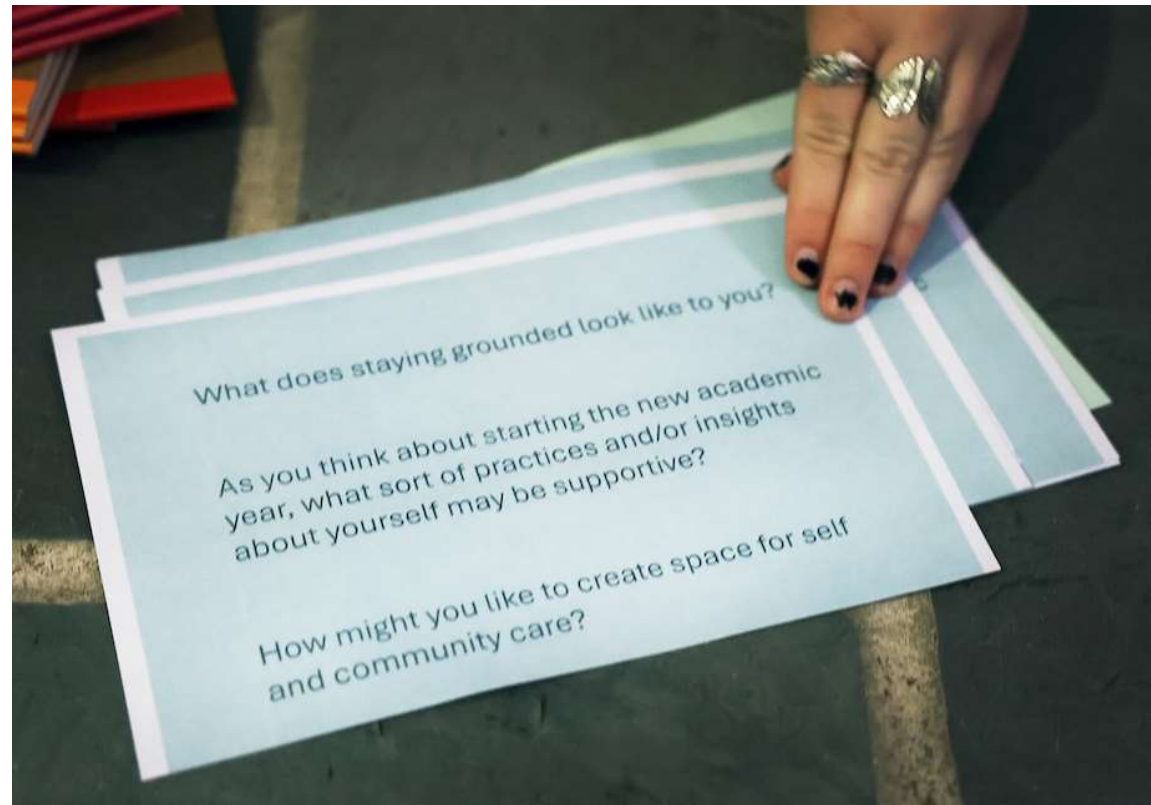



**COLORADO  
COLLEGE**

## Academic Preparedness





**COLORADO  
COLLEGE**

## Academic Preparedness

- Digital dependency
- Literacy
  - Writing
  - Reading
  - Note-taking
- Oral communication
- Math
- Neurodivergence
- Process vs. Product
- Cheating



**COLORADO  
COLLEGE**

## National Reading and Math Scores

	Average Reading Score Change	Average Math Score Change
4th Grade 2019 vs 2022	-3pts	-5pts
8th Grade 2019 vs 2022	-3pts	-8pts
12 Grade 2015 vs 2019	-2pts	-3pts



**COLORADO  
COLLEGE**

## Colorado Reading and Math Scores

	Average Reading Score Change	Average Math Score Change
4th Grade 2019 vs 2022	-2pts	-6pts
8th Grade 2019 vs 2022	-4pts	-10pts





**COLORADO  
COLLEGE**

## Course-Taking Patterns

- Over  $\frac{1}{4}$  of 12th graders took a dual-enrollment course in 2019
- Increased course-taking in healthcare, hospitality, and engineering/technology
- Decreased course-taking in business and marketing



**COLORADO  
COLLEGE**

## Focus

- Affordability & Opportunity
- Career Readiness
- Mental Health & Wellness
- Academic Preparedness

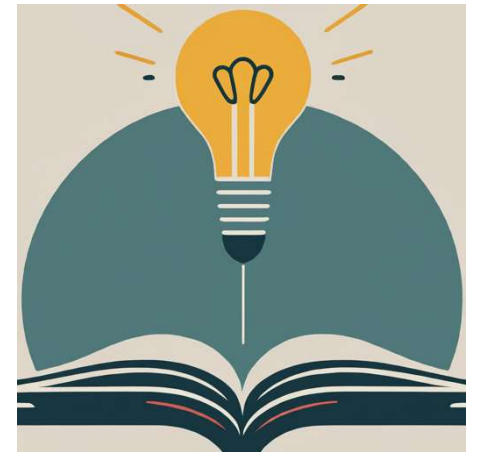
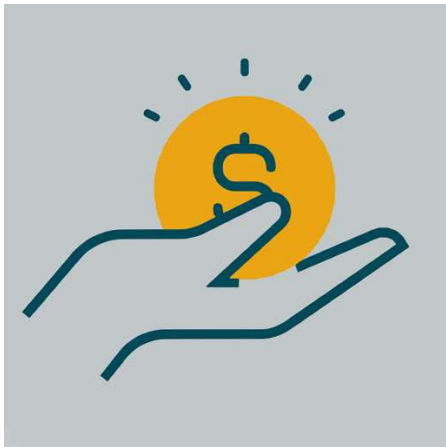





**COLORADO  
COLLEGE**

# What Higher Ed and K-12 Do Differently





**COLORADO  
COLLEGE**

## Higher Ed Strategies

- Pipeline programs
- Financial aid
- Development
- Bridge courses
- Workforce development
- Leadership development
- Mental health and wellness
- Faculty development

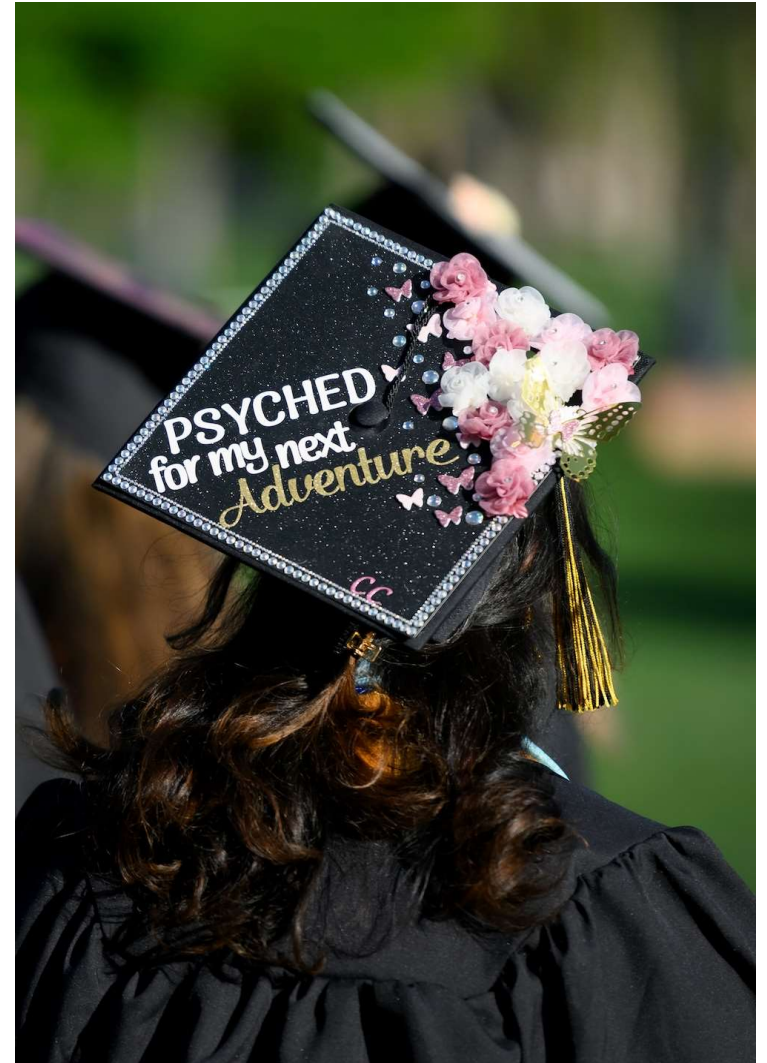



**COLORADO  
COLLEGE**

## **K-12 Strategies**

- Philanthropy
- Social networks
- Policies and procedures
- School counselors
- Family engagement
- Curricular chaos
- Pedagogy pinwheel





**COLORADO  
COLLEGE**

# Change the Blueprint

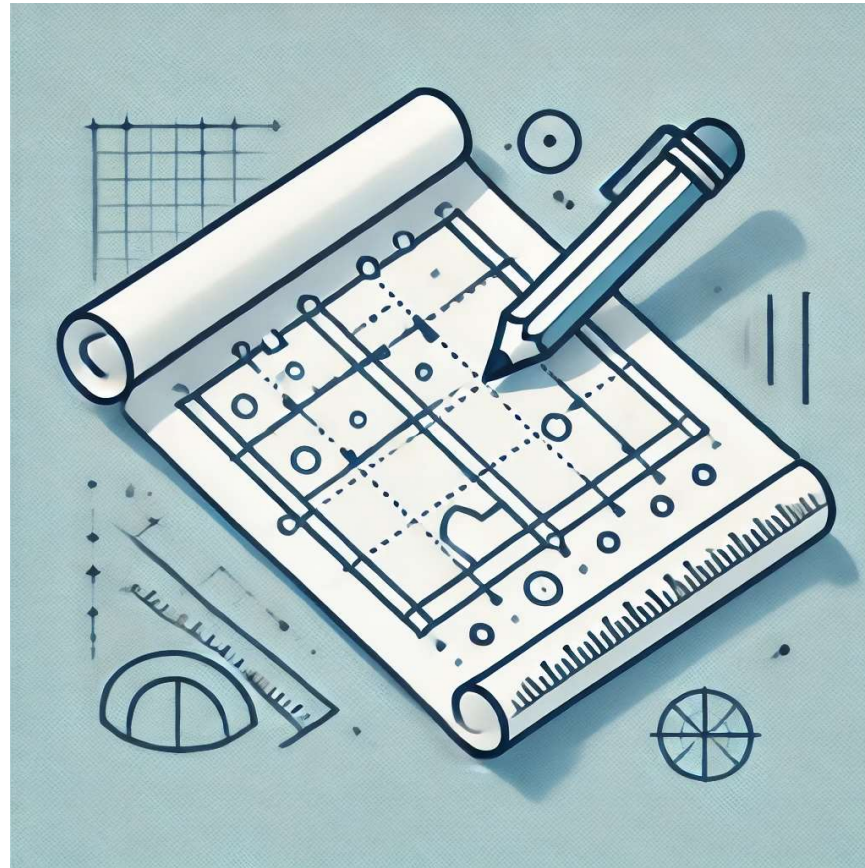



**COLORADO  
COLLEGE**

## Opportunities to Build Infrastructure

- Vision, mission, values
- Policy review
- Program review
- Student outcomes
- Goals
- Needs assessment





**COLORADO  
COLLEGE**

## Opportunities to Build Up

- Curriculum redesign
  - Assessment
  - Technology
- Co-curriculars
- Teacher evaluation
- Teacher advancement





**COLORADO  
COLLEGE**

## Opportunities to Build In

- Organizational structure
  - Advancement division
  - Enrollment division
- Teacher education
- Wellness





**COLORADO  
COLLEGE**

## Opportunities to Build Out

- Market research
- Community partnerships
- College and university partnerships
- Pipeline programs
- Alumni engagement







**COLORADO  
COLLEGE**

## **What Students Get**

- **Affordability and Opportunity**
  - Expanded social network
  - Well-rounded
- **Career Readiness**
  - Legibility
  - Informed decision-making
- **Mental Health and Wellness**
  - Positive development
- **Academic Preparedness**
  - Diverse perspectives that promote learning
  - Soft skills and life experience
  - Cognitive skills



**COLORADO  
COLLEGE**

## What You Get

- **Fiscal Gains**
  - Multiple revenue streams
  - Operational efficiency
- **School Climate**
  - Retention -> morale boost
  - Decreased behavioral referrals
- **Enrollment**
  - Applicant pool
  - Proactive recruitment
  - ROI for parents
- **Academic Mission**
  - Higher student achievement
  - Academic support
  - Expanded/free co-curriculars



**COLORADO  
COLLEGE**

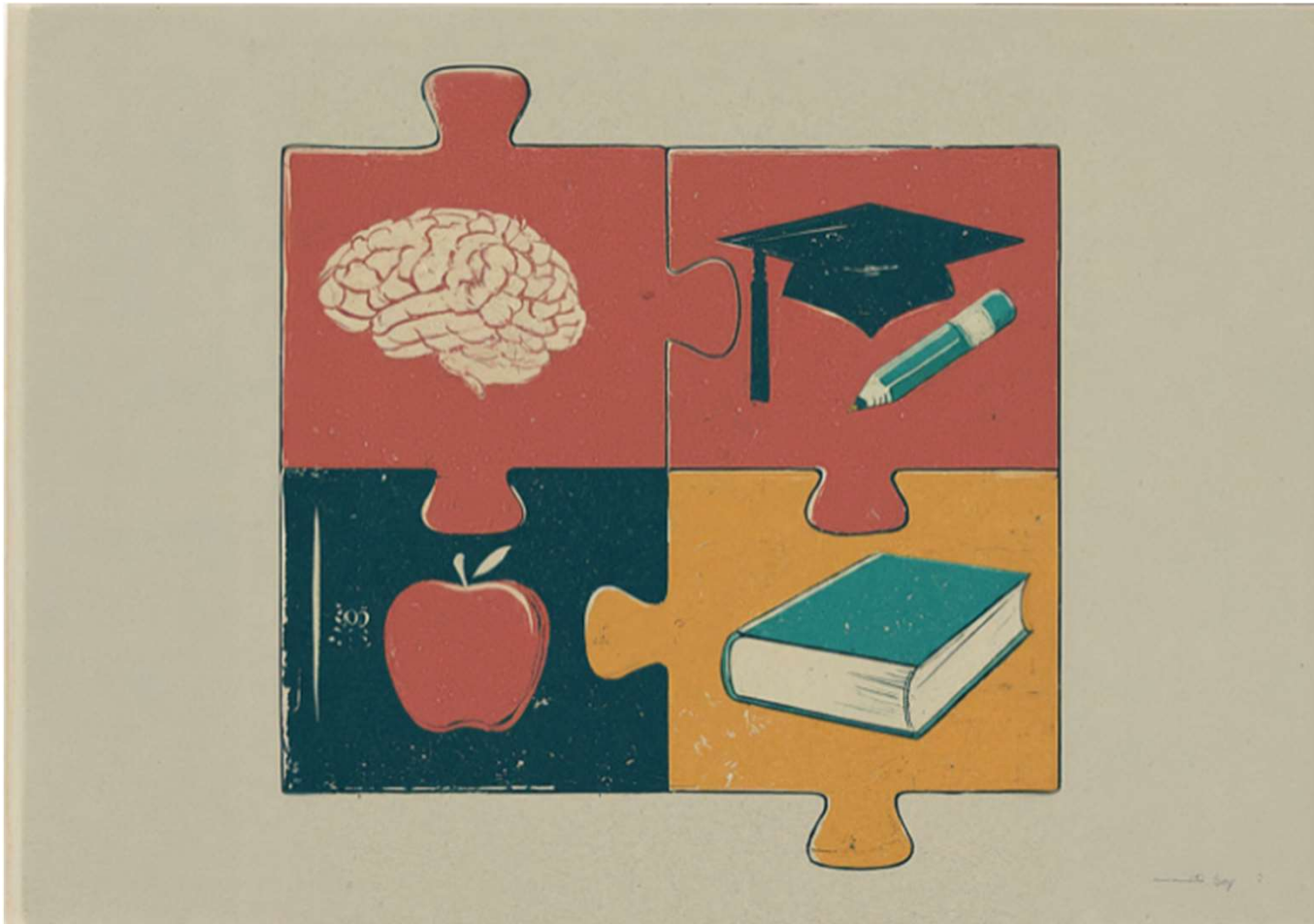



**COLORADO  
COLLEGE**

**Thank You!**

**Questions?**

